

# SR<sup>®</sup> Meters

## Displacement Type Magnetic Drive Cold Water Meters

### 1-1/2" (DN 40mm) and 2" (DN 50mm) Sizes

#### DESCRIPTION

**Applications:** Measurement of cold water where flow is in one direction; in residential, commercial and industrial services.

**Conformance To Standards:** Sensus Sealed Register Water Meters comply with ANSI/AWWA Standard C700, latest revision. Each meter is tested to insure compliance.

**Construction:** Sensus SR Water Meters consist of three basic components: maincase; measuring chamber; permanently, hermetically-sealed register. Maincases are of bronze with either flanges or internally-threaded spuds. Measuring chambers are of Rocksyn<sup>®</sup>, a corrosion-resistant thermoplastic material. Bronze measuring chambers are available as an option.

**Sealed Register:** Permanently, hermetically sealed; proven magnetic drive design; with integral tamper-proof locking device. Guaranteed for 25 years. The standard register includes a straightreading, odometer-type totalization display; a 360° test circle with center sweep hand; and a low flow (leak) detector. Gears are selflubricating, molded plastic for long life and minimum friction. The hermetic sealing of the register eliminates dirt and moisture, tampering, and lens fogging problems.

No change gears are required for accuracy calibration. Encodertype remote reading systems are available for all SR Water Meters. (See back of sheet for additional information.)

**Tamperproof Features:** Removing the register to obtain free water is prevented by a locking device inside the meter. Removing the register requires a special tool that is available only to water utilities.

**Magnetic Drive:** The unique design of the direct magnetic drive is a positive, reliable, dependable drive coupling, proven in millions of SR Water Meters.

**Operation:** Water flows through the meter's strainer and into the measuring chamber where it operates the piston. The piston, which moves freely, oscillates around a central hub, guided by the rubber-coated division plate.

A drive magnet, incorporated in the piston, rotates around the outside of the hermetically sealed register well and magnetically drives the "follower" magnet sealed within the well. The "follower" magnet drives a crank connected to the register gear train, which translate the number of piston oscillations into volume totalization units displayed on the register face.

**Maintenance:** Sensus Sealed Register Water Meters are engineered to provide long-term value and virtually maintenance-free operation because of their design simplicity and interchangeability of modules. Sensus SR



1-1/2" SR<sup>®</sup>  
(DN 40mm)

2" SR<sup>®</sup>  
(DN 50mm)

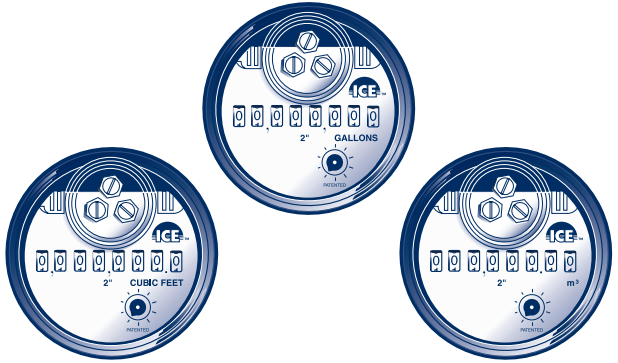

2" (DN 50mm) Dials Shown

Water Meters are easy to repair, even without removing the maincase from the installation. As an alternate to repair by the utility, Sensus offers various maintenance programs which provide factory reconditioning of the maincase and replacement of components at low fixed prices.

**Connections:** Tailpieces/Companion Flanges for installing the meters on a variety of pipe and sizes are available as an option. For flanged meters, the use of a Smith-Blair Model 926 Flanged Coupling Adapter is recommended to facilitate the installation and any future removal of the meter from the line.

**AMR / AMI Systems:** Meters and encoders are compatible with current Sensus AMR/AMI systems.

**Guarantee:** Sensus SR<sup>®</sup> Water Meters are backed by "The Sensus Guarantee." Ask your Sensus representative for details, or see Bulletin G-500.

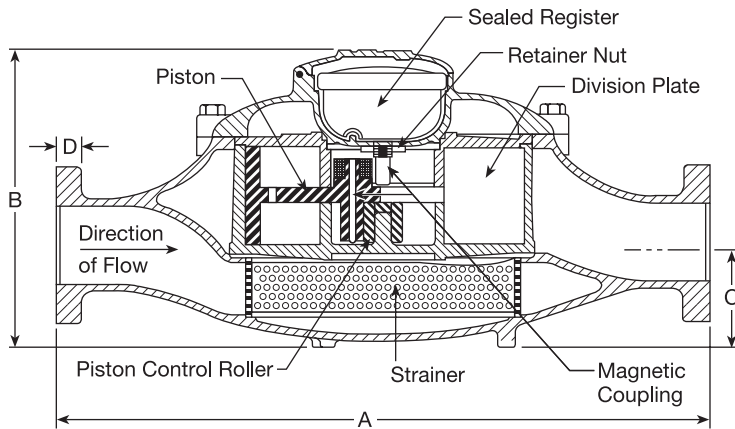

**DIMENSIONS AND NET WEIGHTS**

Meter Size	Connections	A	B	B <sup>4</sup>	C	D	Width	Bolt Circle	Number of Bolts	Bolt Size	Net Weight <sup>1</sup>
1-1/2" (DN 40mm)	Flanged	13 (330mm)	6-7/8 (175mm)	8-3/4" (222mm)	2-21/32 (68mm)	5/8 (16mm)	8-3/4 (222mm)	4 (102mm)	2	5/8 (16mm)	26 lbs. (12 kg)
	Screwed	12-5/8 (322mm)	6-7/8 (175mm)	8-3/4" (222mm)	2-21/32 (68mm)	N/A <sup>2</sup>	8-3/4 (222mm)	N/A <sup>2</sup>	N/A <sup>2</sup>	N/A <sup>2</sup>	23 lbs. (10.5 kg)
2" (DN 50mm)	Flanged	17 (432mm)	7-17/32 (192mm)	9-3/8" (238mm)	2-5/8 (67mm)	5/8 (16mm)	9-11/16 (246mm)	4-1/2 (115mm)	2	3/4 (19mm)	42 lbs. (19 kg)
	Screwed	15-1/4 (388mm)	7-17/32 (192mm)	9-3/8" (238mm)	2-5/8 (67mm)	N/A <sup>3</sup>	9-11/16 (246mm)	N/A <sup>3</sup>	N/A <sup>3</sup>	N/A <sup>3</sup>	37 lbs. (17 kg)

<sup>1</sup> With Rocksyn measuring chamber. Meter is available with either flanged or screwed end connections. Flanged end meter illustrated to show oval flange and bolt pattern. End connection threads:  
<sup>2</sup> 1-1/2" (DN 40mm)—1-1/2" N.P.T. Internal Threads or 1-1/2" ISO R-7 International Threads, if specified  
<sup>3</sup> 2" (DN 50mm)—2" N.P.T. Internal Threads or 2" ISO R-7 International Threads, if specified.  
<sup>4</sup> The measurement to the top of a TR/PL on an ICE register.

**SPECIFICATIONS**

<b>SERVICE</b>	Measurement of cold water with flow in only one direction.
<b>NORMAL OPERATING FLOW RANGE <sup>1</sup></b>	1-1/2" (DN 40mm) size: 5 to 100 gal/min. (1.1 to 23.0 m <sup>3</sup> /h) 2" (DN 50mm) size: 8 to 160 gal/min. (1.8 to 36.0 m <sup>3</sup> /h)
<b>ACCURACY</b>	100% ± 1.5% of actual thruput
<b>LOW FLOW REGISTRATION</b>	1-1/2" (DN 40mm) size: 95% at 1-1/2 gal/min. (0.35 m <sup>3</sup> /h) 2" (DN 20mm) size: 95% at 2 gal/min. (0.45 m <sup>3</sup> /h)
<b>MAXIMUM PRESSURE LOSS</b>	1-1/2" (DN 40mm) size: 11.4 psi at 100 gal/min. (0.8 bar at 23.0 m <sup>3</sup> /h) 2" (DN 50mm) size: 12.1 psi at 160 gal/min. (0.8 bar at 36.0 m <sup>3</sup> /h)
<b>MAXIMUM OPERATING PRESSURE</b>	150 psi (10.0 bar)
<b>MEASURING ELEMENT</b>	Oscillating piston
<b>REGISTER</b>	Straight reading, hermetically sealed, magnetic drive with low flow indicator. Remote reading unit optional.
<b>REGISTRATION</b>	100,000,000 gallons, 100 gallon/sweep hand revolution 10,000,000 cubic feet 10 cubic feet/sweep hand revolution 100,000 m <sup>3</sup> 0.1 m <sup>3</sup> /sweep hand revolution

<b>METER CONNECTIONS <sup>2</sup></b>	1-1/2" (DN 40mm) size: two bolt oval flanged spuds or 1-1/2" (DN 47.80mm) internal pipe threads 2" (DN 50mm) size: two bolt oval flanged spuds or 2" (59.61mm) internal pipe threads (Threads are taped pipe, internal type, conforming to ANSI B1.20.1 or ISO R-7 if specified. Flanges are AWWA 125 pounds [PN 10 bar] class.)
<b>MATERIALS</b>	Maincase—Bronze Measuring chamber—Rocksyn Magnets—ceramic and Alnico Strainer—Thermoplastic Trim—Stainless Steel Casing bolts—Stainless Steel

<sup>1</sup> Maximum rates listed are for intermittent flow only. Maximum continuous flow rates as specified by AWWA are:  
 1-1/2" (DN 40mm) size: 50 gal/min (11.0 m<sup>3</sup>/h)  
 2" (DN 50mm) size: 80 gal/min (18.0 m<sup>3</sup>/h)  
<sup>2</sup> Flanged spuds are standard for 1-1/2" (DN 40mm) and 2" (DN 50mm) size meters and will be furnished unless otherwise specified. Internal tapped pipe threads only are supplied for ISO meters.

AUTHORIZED SENSUS DISTRIBUTOR



P.O. Box 487 | 450 North Gallatin Avenue  
 Uniontown, PA 15401 USA  
 T: 1-800-638-3748  
 F: 1-800-888-2403  
 www.sensus.com/water  
 h2oinfo@sensus.com